

## Centralized Residential and Commercial Heating Solutions

Eco Therm Services SRL Craiova is specialised in providing integrated centralized heating solutions - from initial survey to system design, product supply, ongoing trouble-free maintenance and a comprehensive support package including , heat interface units for centralized heating systems, energy metering, billing and a revenue management service.

Our combined forces, intelligent solutions and consistent customer orientation help our customers all over to use natural resources and energy efficiently and sensibly – for economic success, for ecological sustainability, and for mankind. **Supplying intelligent metering technology enables customers** to handle natural resources and energy in a highly efficient way. Whether over Radio, M-Bus, GPRS or LAN, automatic meter reading (AMR) makes water, thermal energy, gas and electricity consumption data available in the shortest possible time – for energy utilities and for end consumers.

### Our Clients and Projects Include:

- Refurbishment Projects
- **Social Housing**
- Private Developments
- Housing Associations
- Local Authorities
- **Housing Developers**
- **Mechanical & Electrical Consultants**
- Managing Agents
- Utility Companies



With more than 11 years of experience in the Communal/District heating market, Eco Therm Services have been involved in the design and supply of equipment for many projects for both private and Municipal housing schemes. Our range of DH substation and heat interface units are designed and developed internally and manufactured in our own production facility, according with customer or end user demand.

### EcoTherm Services production is carried out in accordance with a Integrated Management System



SR EN ISO 9001:2008



SR EN ISO 14001:2005



SR OHSAS 18001:2008



ISO/IEC 27001:2013

## Production

### Central Plant - large substation up to 3MWh FOR COMMUNAL & DISTRICT HEATING SYSTEMS

A centralised plant room forms the heart of a Centralized District Heating system, delivering energy to each dwelling via a main heating primary circuit. This is in line with latest legislation encouraging centralised plant connected to a heat network, rather than the use of individual heating and hot water systems.



### Heat Interface Units (HIU)

Our range of heat interface units, for Communal / District heating systems, are designed and developed by us in the Romania and manufactured in our own production facility.

**With a large range of models available, the system suits a variety of applications such as:**

- Small flats
- Private housing developments
- Large luxury apartments
- Sheltered accommodation
- Student accommodation

Our ETS Confort HIU's have been tested according with CertIND SIM regulations and the results demonstrate that the units surpassed benchmark requirements set out in the UE regulations for Heat Network Code of Practice, for both duty and return temperature performance.

Sometimes referred to as a heat board, HIU, heat interface or a hydraulic interface unit, the ETS Confort consists of either high capacity heat exchangers for instantaneous hot water and direct heating supply, or a single plate heat exchanger for the hydraulic break and an integrated fast recovery DHW tank.

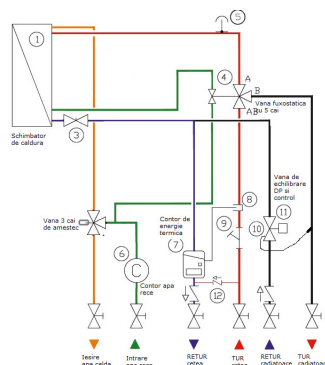

## Metering and Complete solutions for mobile reading and fixed network

Our strategy for more performance Eco Therm Services stands for the efficient use of water, thermal energy, gas and electricity. Our goal is to optimize all processes – from consumption measurement and meter reading to data management and services.

We provide :

- Metering equipment for water, heating/cooling, gas and electricity
- Project solutions from planning to operation
- Different communication technologies for wired and wireless applications
- High actuality and quality of data
- Radio, M-Bus, GPRS or LAN data reading system
- Complete package of software solutions from reading to meter data management



## IZAR@NET / IZAR WEB SERVER

Central platform for all energy data The IZAR@NET and IZAR WEB SERVER enables the organization of all processes at a glance – from meter reading, data management and analysis to billing preparation. The IZAR MDM software supports mobile automatic meter reading as well as the operation of a fixed network. Consumption data for water, thermal energy, gas and electricity are managed centrally. As a part of Energy Efficiency program for water and energy , IZAR@NET software is intended for energy utilities, municipal associations and local authorities, large industrial companies and local heating utilities. On request we take over the administration, maintenance work and updates for meter management, so energy utilities can concentrate on their core processes. The application is accessible over the Internet browser at any time and further software installations are no longer required.

Benefit for consumers, companies and the environment With the IZAR@NET as basis the possibilities for process optimization are unlimited. For example, leak detection not only saves water, but above all the resulting cost of repairing the damage. In heating networks, substantial savings in costs can be achieved by optimizing the forward and return temperature – this reduces the amount of water and fuel required, the pump power and the emission of CO2 and other pollutants. Through the IZAR@NET utilities can also offer their end consumers totally new added values in future, for example, via consumer apps. These provide the basis for better communication between utilities and consumers, who can then get to know and optimize their consumption better.



**SC ECO THERM SERVICES SRL**

**Sediu Social:**

Str. Ion Ţuculescu Nr. 13, Bl. V6, Ap.15, Craiova, jud. DOLJ

**Birouri/Depozit/Producție :**

DC 87, Loc. PieleŃti, 207450, jud. DOLJ

Tel: +4 0374040426; Fax: +4 0374092501; Web: [www.etserv.ro](http://www.etserv.ro)

E-mail: [office@etserv.ro](mailto:office@etserv.ro)